

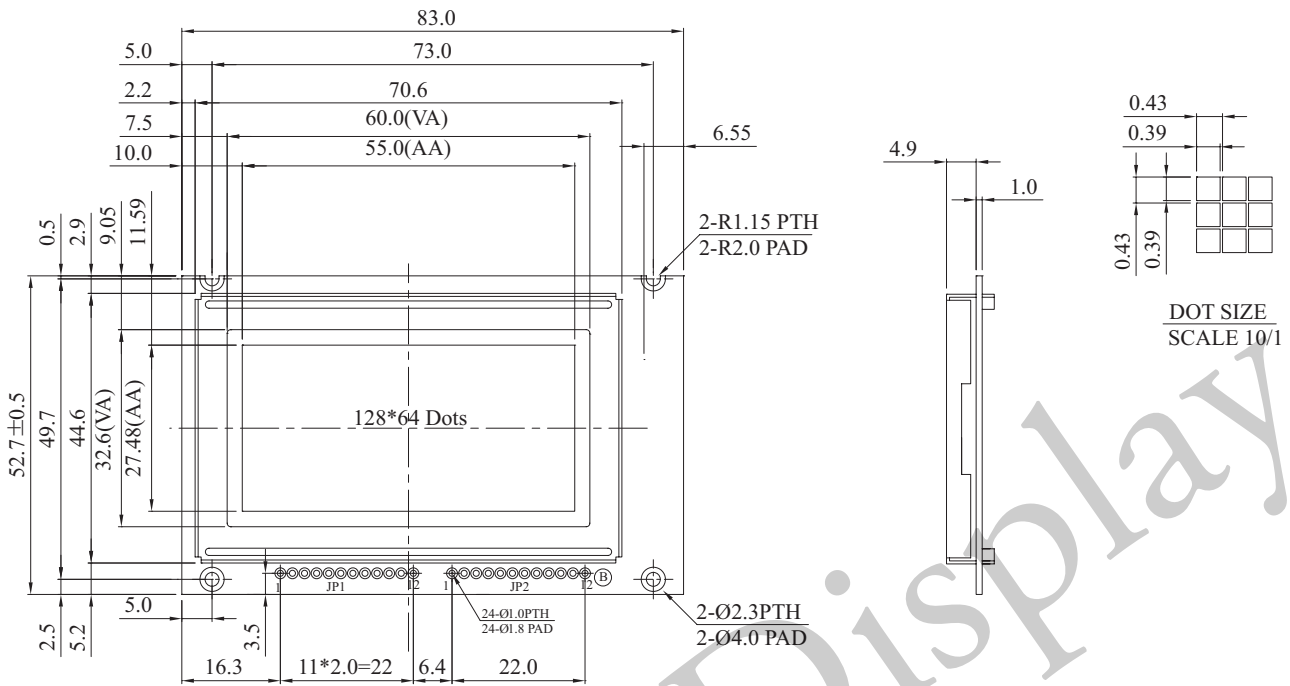

WG12864P3/P5 Graphic 128x64 dots

Dimension drawing



Feature

1. 128x64 dots includes cursor
2. Built-in controller ST7920
3. +3V/ +5V power supply
4. 1/32 duty cycle
5. N.V.Built-in

JP1

Pin NO.	Symbol	Description
1	VDD	Supply voltage for logic
2	VSS	Ground
3	VO	Supply voltage for LCD
4	RS	H: Data , L : Instruction
5	R/W	H: Read (MPU←Module) ; L: Write (MPU→Module)
6	E	ENABLE SIGNAL
7	DB0	Data bus line
8	DB1	Data bus line
9	DB2	Data bus line
10	DB3	Data bus line
11	DB4	Data bus line
12	NC	NC

JP2

1	DB5	Data bus line
2	DB6	Data bus line
3	DB7	Data bus line
4	RST	Reset LCM
5	Vout	Positive voltage for LCD
6	A	Power Supply for LED backlight (+)
7	K	Power Supply for LED backlight (-)
8	SL0	
9	KBIN4	
10	KBIN5	
11	KBIN6	
12	NC	NC

Mechanical Data

Item	Standard Value	Unit
Module dimension	83.0 x 52.7	mm
Viewing area	60.0 x 32.6	mm
Mounting hole	73.0 x 49.7	mm
Dot Size	0.39 x 0.39	mm
Dot Pitch	0.43 x 0.43	mm

Absolute Maximum Rating

Item	Symbol	Standard Value			Unit
		min.	typ.	max.	
Power Supply	VDD-VSS	2.7	---	5.0	V
Input Voltage	VI	0	---	VDD	V

Note: VSS=0 Volt, VDD=3.0/5.0 Volt.

Electronical Characteristics

Item	Symbol	Condition	Standard Value			Unit
			min.	typ.	max.	
Input Voltage	VDD-VSS	-	2.7	3.0	3.3	3V
			4.5	5.0	3.5	5V
Supply Current	IDD	VDD=3V5V	-	2.8	-	mA
Recommended LC Driving Voltage for Normal Temp. Version module	VDD-V0	-20°C	-	-	-	V
		25°C	4.8	5.5	6.0	
		+70°C	-	-	-	
LED Forward Voltage	VF	25°C	3.4	3.5	3.6	V
LED Forward Current	IF	25°C	43.2	48	60	mA

Graphic type